

ALUMINUM WELDMENT PIPE TO PIPE, Y, PERPENDICULAR MAIN

SECTION

18-5

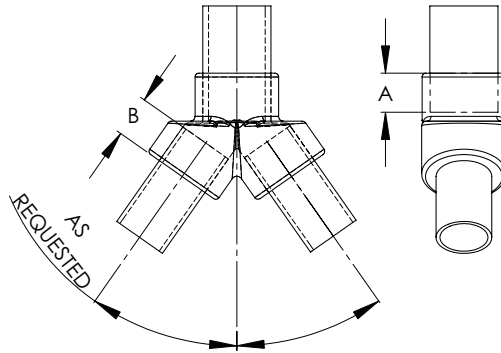

ALUMINUM WELDMENT CONNECTORS PIPE TO PIPE, Y, PERPENDICULAR MAIN				
CATALOG NUMBER	IPS MAIN	IPS TAP	DIMENSIONS IN INCHES	
			A	B
18-413	1/2	1/2	1	1
18-414	3/4	1/2	1	1
18-415	3/4	3/4	1	1
18-416	1	1/2	1 1/4	1
18-417	1	3/4	1 1/4	1
18-418	1	1	1 1/4	1 1/4
18-419	1 1/4	1/2	1 1/4	1
18-420	1 1/4	3/4	1 1/4	1
18-421	1 1/4	1	1 1/4	1 1/4
18-422	1 1/4	1 1/4	1 1/4	1 1/4
18-423	1 1/2	1/2	1 1/2	1
18-424	1 1/2	3/4	1 1/2	1
18-425	1 1/2	1	1 1/2	1 1/4
18-426	1 1/2	1 1/4	1 1/2	1 1/4
18-427	1 1/2	1 1/2	1 1/2	1 1/2
18-428	2	1/2	1 3/4	1
18-429	2	3/4	1 3/4	1
18-430	2	1	1 3/4	1 1/4
18-431	2	1 1/4	1 3/4	1 1/4
18-432	2	1 1/2	1 3/4	1 1/2
18-433	2	2	1 3/4	1 3/4
18-434	2 1/2	1/2	2	1
18-435	2 1/2	3/4	2	1
18-436	2 1/2	1	2	1 1/4
18-437	2 1/2	1 1/4	2	1 1/4
18-438	2 1/2	1 1/2	2	1 1/2
18-439	2 1/2	2	2	1 3/4
18-440	2 1/2	2 1/2	2	2
18-441	3	1/2	2 1/4	1
18-442	3	3/4	2 1/4	1
18-443	3	1	2 1/4	1 1/4
18-444	3	1 1/4	2 1/4	1 1/4
18-445	3	1 1/2	2 1/4	1 1/2
18-446	3	2	2 1/4	2 1/2
18-447	3	2 1/2	2 1/4	2 1/2
18-448	3	3	2 1/4	2 3/4
18-449	3 1/2	1/2	2 1/2	1
18-450	3 1/2	3/4	2 1/2	1
18-451	3 1/2	1	2 1/2	1 1/4
18-452	3 1/2	1 1/4	2 1/2	1 1/4
18-453	3 1/2	1 1/2	2 1/2	1 1/2
18-454	3 1/2	2	2 1/2	1 3/4
18-455	3 1/2	2 1/2	2 1/2	2
18-456	3 1/2	3	2 1/2	2 1/4
18-457	3 1/2	3 1/2	2 1/2	2 1/2
18-458	4	1/2	2 1/2	1
18-459	4	3/4	2 1/2	1
18-460	4	1	2 1/2	1 1/4

If an economical and permanent union is required between a pipe main and taps whose angles vary from the perpendicular, the Type TTWP proves an efficient connector. Durable and lightweight because of its high conductivity aluminum alloy, it can be especially useful in self-supporting A-frame structures.

Varying angles should be noted by means of a suffix added to the catalog number. If a 15½ angle tap is needed for catalog number 18-413, for instance, the number should be written on the order as 18-413-15.



Continued on next page

SECTION

18-5

ALUMINUM WELDMENT PIPE TO PIPE, Y, PERPENDICULAR MAIN

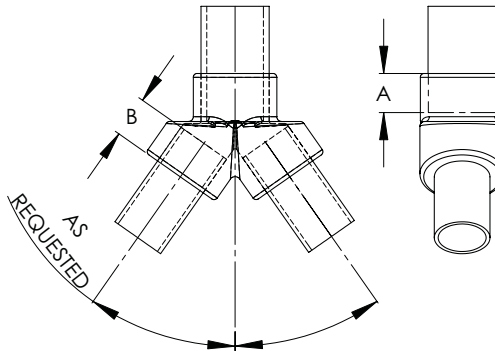

Continued from previous page

ALUMINUM WELDMENT CONNECTORS PIPE TO PIPE, Y, PERPENDICULAR MAIN (Cont'd)				
CATALOG NUMBER	IPS MAIN	IPS TAP	DIMENSIONS IN INCHES	
			A	B
18-461	4	1 1/4	2 1/2	1 1/4
18-462	4	1 1/2	2 1/2	1 1/2
18-463	4	2	2 1/2	1 3/4
18-464	4	2 1/2	2 1/2	2
18-465	4	3	2 1/2	2 1/4
18-466	4	3 1/2	2 1/2	2 1/2
18-467	4	4	2 1/2	2 1/2
18-468	4 1/2	1/2	2 3/4	1
18-469	4 1/2	3/4	2 3/4	1
18-470	4 1/2	1	2 3/4	1 1/4
18-471	4 1/2	1 1/4	2 3/4	1 1/4
18-472	4 1/2	1 1/2	2 3/4	1 1/2
18-473	4 1/2	2	2 3/4	1 3/4
18-474	4 1/2	2 1/2	2 3/4	2
18-475	4 1/2	3	2 3/4	2 1/4
18-476	4 1/2	3 1/2	2 3/4	2 1/2
18-477	4 1/2	4	2 3/4	2 1/2
18-478	4 1/2	4 1/2	2 3/4	2 3/4
18-479	5	1/2	2 3/4	1
18-480	5	3/4	2 3/4	1
18-481	5	1	2 3/4	1 1/4
18-482	5	1 1/4	2 3/4	1 1/4
18-483	5	1 1/2	2 3/4	1 1/2
18-484	5	2	2 3/4	1 3/4
18-485	5	2 1/2	2 3/4	2
18-486	5	3	2 3/4	2 1/4
18-487	5	3 1/2	2 3/4	2 1/2
18-488	5	4	2 3/4	2 1/2
18-489	5	4 1/2	2 3/4	2 3/4
18-490	5	5	2 3/4	2 3/4
18-491	6	1/2	3	1
18-492	6	3/4	3	1
18-493	6	1	3	1 1/4
18-494	6	1 1/4	3	1 1/4
18-495	6	1 1/2	3	1 1/2
18-496	6	2	3	1 3/4
18-497	6	2 1/2	3	2
18-498	6	3	3	2 1/4
18-499	6	3 1/2	3	2 1/2
18-500	6	4	3	2 1/2
18-501	6	4 1/2	3	2 3/4
18-502	6	5	3	2 3/4
18-503	6	6	3	3

